

NTN[®]

Asymmetrical Spherical Roller Bearings for Wind Turbine Main Shafts

CAT. No. 3038/E

Asymmetric design of left and right roller rows

Longer operating life and
better wear-resistance characteristics

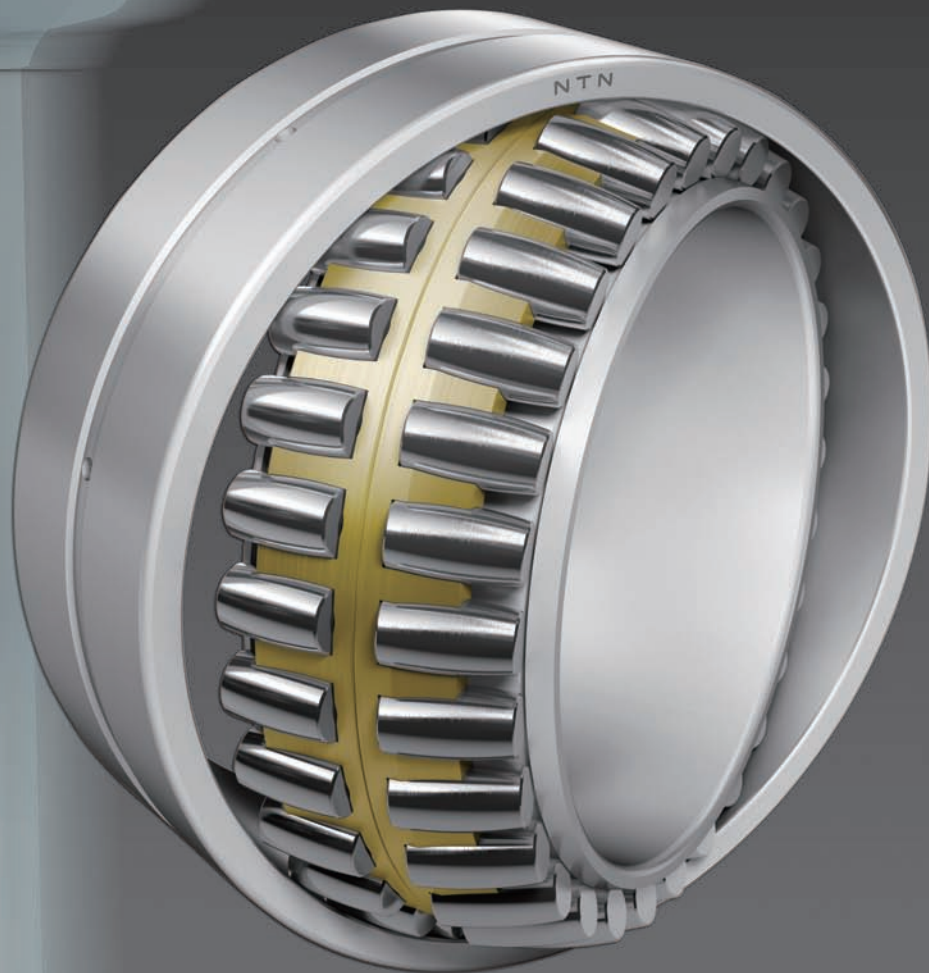
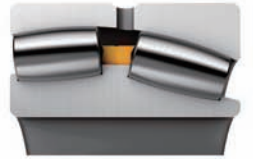

Asymmetrical Spherical Roller Bearings for Wind Turbine Main Shafts

Next generation bearings delivering *innovation* to wind power generation



Asymmetric design of left and right roller rows for longer operating life and better wear-resistance characteristics

Wind turbine main shaft bearings are subjected to axial loading caused by wind loads, in addition to radial loads from the weight of components including the rotors and blades. The use of spherical roller bearings for such applications results in the rear row (power generator side) being subjected to large loads while the front row is more lightly loaded (see Fig. 1). Additionally, spherical roller bearings have a characteristic of rolling and sliding due to inherent internal geometry.*1 These conditions, combined with insufficient lubrication at the roller/raceway contact, lead to wear at the raceway surface in areas with a high PV value.*2 As a result, damage might occur, particularly in the outer ring of the rear side.

Asymmetrical spherical roller bearings for wind turbine main shafts have an asymmetrical design of the internal left and right roller rows. This allows the left and right roller rows to distribute loads more evenly, giving the bearings a longer operating life and better wear-resistance characteristics compared to conventional spherical roller bearings.

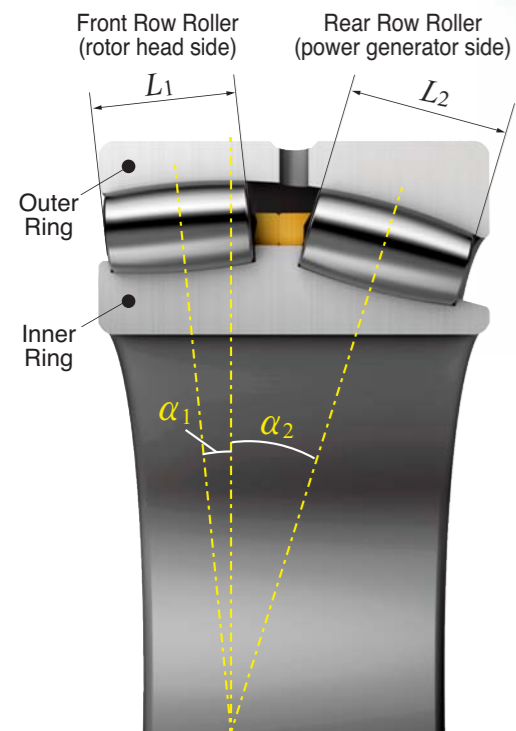
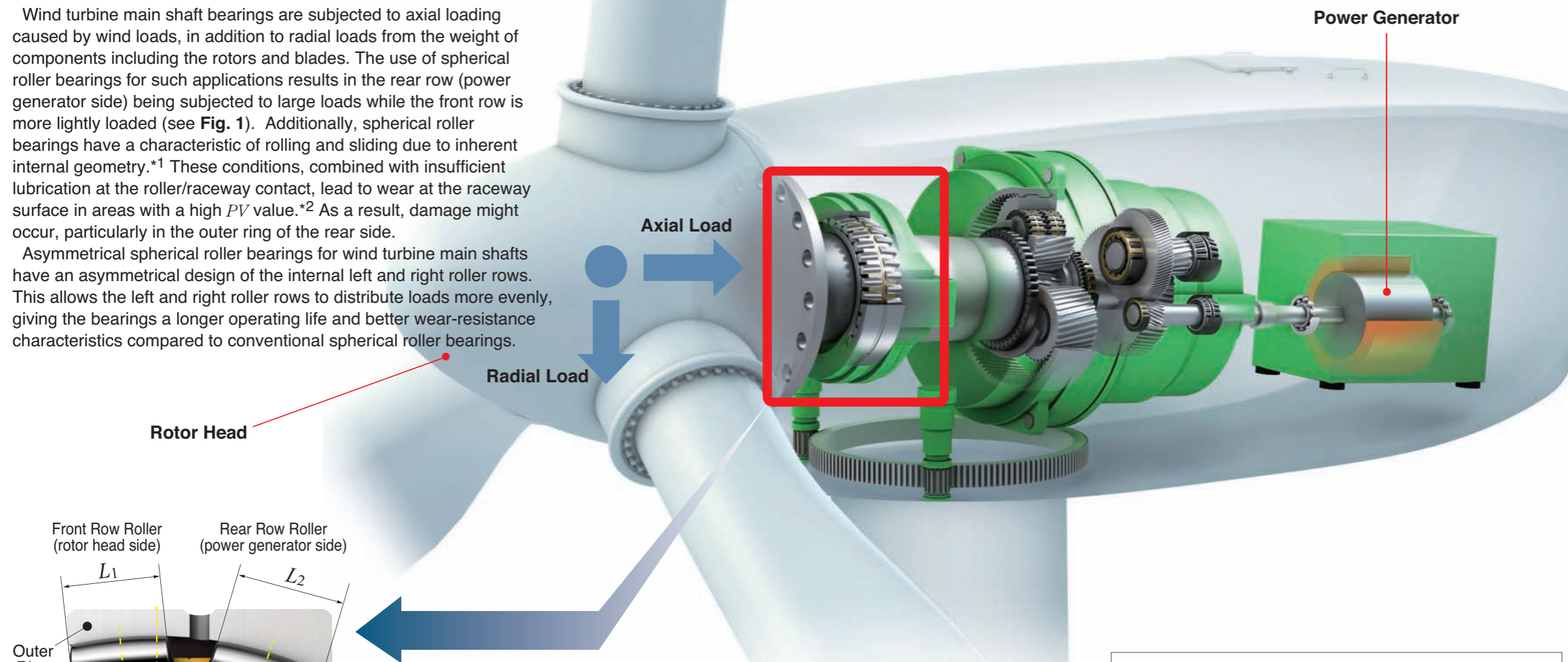

Design specifications of the developed product

- ▷ Contact angle : $\alpha_2 > \alpha_1$ (α_1 : front row contact angle, α_2 : rear row contact angle)
- ▷ Roller length : $L_2 > L_1$ (L_1 : front row roller length, L_2 : rear row roller length)
- ▷ Cage design : separate brass cages for left and right rows
- ▷ Inner ring design : with inner ring center rib
- ▷ Roller design : asymmetrical rollers (with maximum roller diameter position towards the bearing center)

*1 Rolling sliding: sliding caused by the difference in speeds between the contact areas of the roller and raceway surface in the direction of rotation
 *2 PV value: value combining the contact surface pressure [P] and rolling sliding velocity [V].
 *3 Compared with NTN's conventional products (calculated by NTN under average fatigue load conditions acting on wind turbine main shaft bearings)
 *4 When the rollers in roller bearings tilt away from the correct rotating axis

Features

- **Asymmetric design of left/right roller rows:**
Asymmetric bearing design with different length and contact angles between the rollers in the left and right rows
- **Increased wear-resistance:**
Better wear-resistance characteristics due to a reduction in PV value*2 of approximately 30%*3
- **Extended operating life:**
Approximately 2.5-times*3 longer life when compared to theoretical life of the standard product

Compared to conventional products, the contact angle of the developed product is smaller at the front row and larger at the rear row. Additionally, the length of the rear row is longer than the front row, allowing for more efficient support of axial loads from the wind on the rear row and better support of radial loading on the front row. The asymmetric spherical roller bearing is designed with a central rib on the inner ring. The maximum diameter position of the roller is located towards the center of the inner ring to prevent roller skewing.*4

Solutions from NTN

Solution 1

An asymmetric spherical roller bearing design can be selected with the same boundary dimensions as the conventional product, resulting in longer theoretical operating life and better wear-resistance characteristics.



Solution 2

An asymmetric spherical roller bearing design can be selected with approximately 10% reduction in inner diameter and 30% reduction in weight to achieve a similar theoretical operating life as the conventional product.

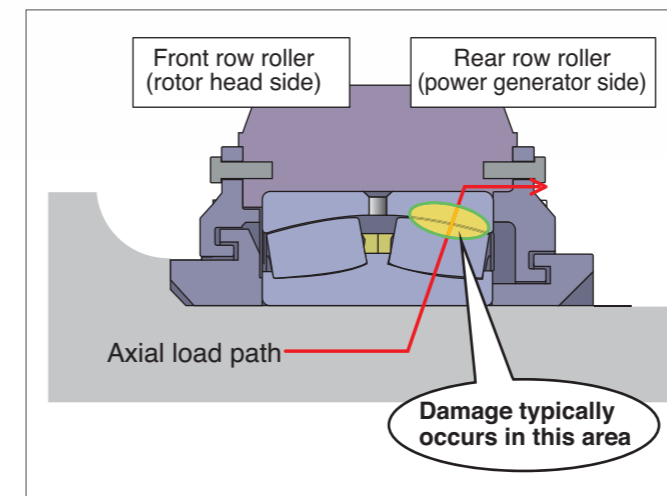
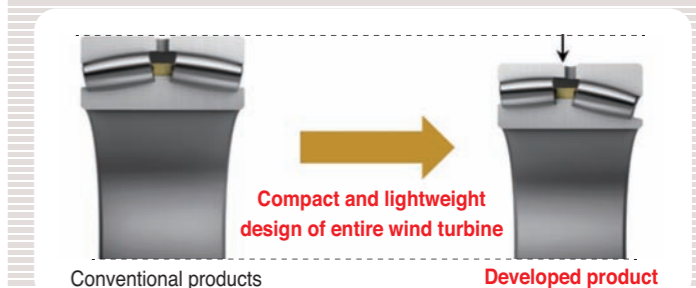

Fig. 1 Axial load acting on wind turbine main shaft bearing